

Bambu Lab Cutting Module

Quick Start Guide

Please review the entire guide for assembly.



SC001



Video Guide

Watch a step-by-step video and get started quickly.

bambulab.com/support/unboxing



Download Bambu Handy and Bambu Studio

Remotely control your printer and monitor your prints in real time on both your phone and computer.

bambulab.com/download



Explore More Cool Models

Visit MakerWorld, our models community, to find a variety of free models and bring your ideas to life using the creativity tools in MakerLab and accessories in Maker's Supply.

makerworld.com



Learn with Bambu Academy

Visit Bambu Academy and explore printer and software courses from beginner to advanced levels to enhance your 3D printing skills.

bambulab.com/support/academy

Table of Contents

1. Safety information.....	4
2. Cutting module component introduction.....	6
3. Included accessories.....	7
4. Print tools in advance.....	8
5. Install on H2D/H2D Pro/H2C.....	9
5.1 Lower the heatbed.....	10
5.2 Install the cutting platform.....	11
5.3 Install the cutting module-H2D/H2D Pro/H2C.....	12
5.4 How to use the drawing function-H2D/H2D Pro/H2C.....	17
5.5 Install the pen module-H2D/H2D Pro/H2C.....	18
6. Install on H2S.....	22
6.1 Lower the heatbed.....	23
6.2 Install the cutting platform.....	24
6.3 Install the cutting module-H2S.....	25
6.4 How to use the drawing function-H2S.....	31
6.5 Install the pen module-H2S.....	31
7. Install on A2L.....	36

Table of Contents

7.1 Raise the toolhead height.....	37
7.2 Install the cutting platform.....	38
7.3 Install the cutting module-A2L.....	39
7.4 How to use the drawing function-A2L.....	45
7.5 Install the pen module-A2L.....	46
8. First calibration and use.....	50
9. Regular maintenance.....	51
10. Specifications.....	52
11. Technical Support.....	53

1. Safety information



Before using the cutting module, ensure you read the instructions carefully to ensure safe and proper operation.

General information:

- Keep your workspace clean and organized, ensuring that tables, shelves, and any structures holding the device are stable and secure.
- Inspect the device thoroughly for any signs of damage before use. If damage is detected, stop using the device immediately.
- Do not disassemble or alter the device's structure and operating methods unless directed by Bambu Lab support.
- Operate the cutting module within a temperature range of 0 °C to 30 °C and store it between -10 °C and 40 °C. To prevent damage, avoid operating or storing the cutting module outside these specified temperatures, or in a strong magnetic field.

Safe cutting:

- Do not operate the cutting module unless it is correctly installed with all safety locking and detection mechanisms active.
- **Do not hold materials by hand during cutting.**
- If the cutting module becomes jammed or obstructed, immediately cut off the printer's power. Wait for all moving parts to stop before disconnecting the cutting module connector. Only then can you handle the module and material.
- It is recommended to use the unloaded to remove the blade from the holder, to prevent injuries while handling by hand. Please visit our Wiki and get detailed guidance.
- After removing the blade, ensure the rubber protective cover is securely in place, and store

1. Safety information

the blade out of reach of children to prevent accidents.

- Before starting the cutting process, ensure the material is securely fastened to prevent it from becoming loose, which could damage the device or cause injury.
- When taking off materials, please pay attention to the blade to prevent injury.

2. Cutting module component introduction

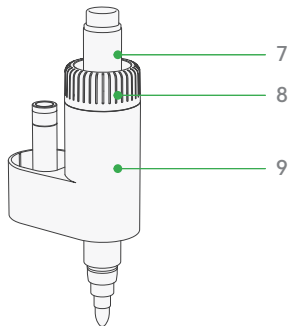
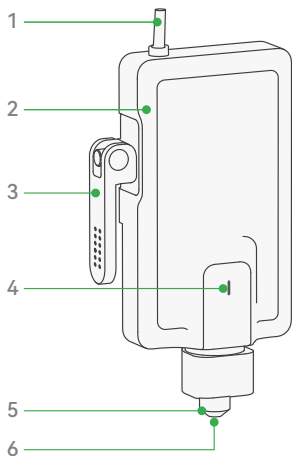

- 1) Connector
- 2) Cutting Module Base
- 3) Quick Release Lever
 - Vertical to the module: Unlocked status.
 - Parallel to the module: Locked status.
- 4) Status Indicator
- 5) Blade Holder
- 6) Blade
- 7) Pen
- 8) Pen Fixture
- 9) Pen Adapter

3. Included accessories



1) Cutting Module

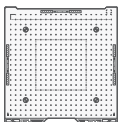

2) Cutting Platform
(Pre-installed with LightGrip
and StrongGrip Cutting Mats)

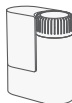

3) Pen Module



4) 45° Fine-point Blade
and Protective Cover



5) Weeding Tool



6) Pen (Black)



7) Pen (Red)



8) Greeting Card
105 * 148 mm
(Material)



9) Black Matte
Heat Transfer Vinyl
300 * 300 mm
(Material)

4. Print tools in advance



Weeding Tool Holder

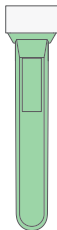

Scraper Blade Holder

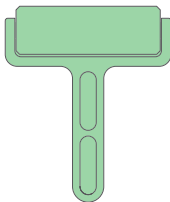

Roller



Blade Holder Unloader

Before using the cutting function, please visit makerworld.com/en/@BambuLab, and then download and print the 3 tools shown above:

- **Weeding tool:** Removes waste after cutting.
- **Scraper blade:** Takes off the material from the cutting platform.
- **Roller:** Used to flatten the material to ensure cutting accuracy.
- **Blade Holder Unloader:** Remove and install the blade holder and blade.

5. Install on H2D/H2D Pro/H2C

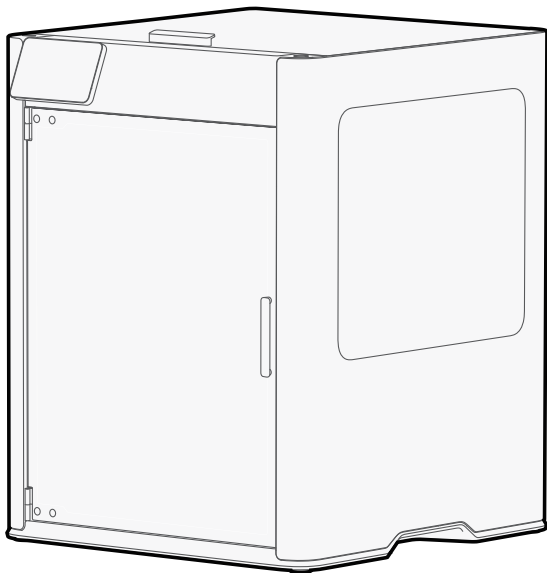

The installation instructions in this section apply to the H2D, H2D Pro, and H2C.

5.1 Lower the heatbed

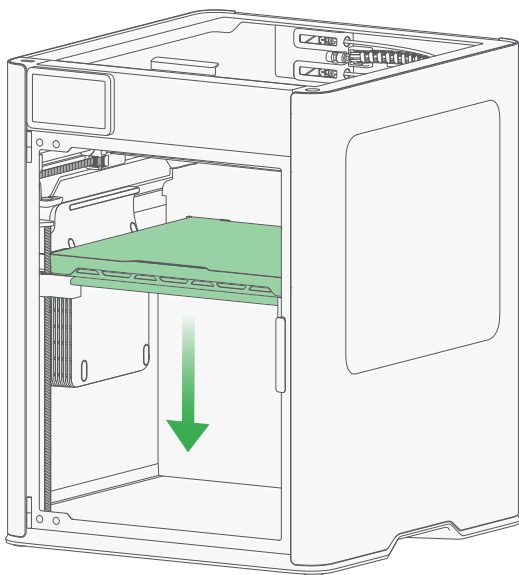

Lower the heatbed using the on-screen buttons to leave enough space to prevent the blade from damaging the cutting platform.

5.2 Install the cutting platform

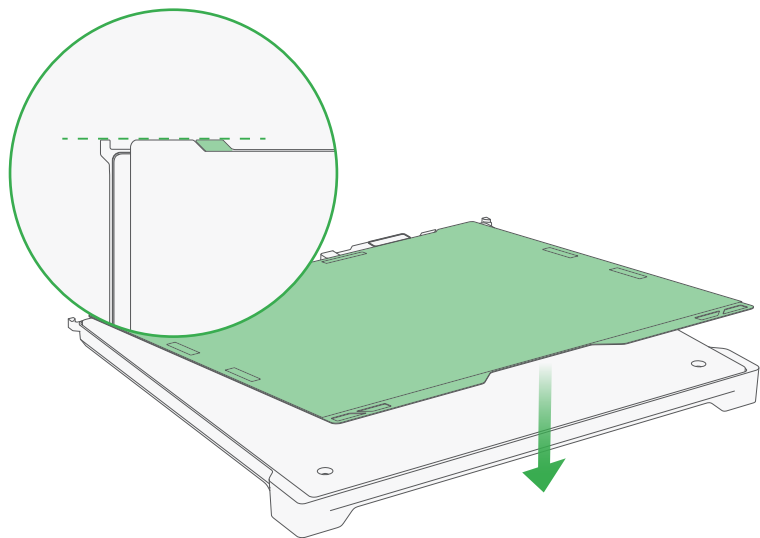

Remove the build plate on the heatbed. Then, place the cutting platform on the heatbed, and make sure to align the two corners of the cutting platform and the stoppers of the heatbed. **Do not discard the protective films on both the cutting mats. After use, reapply the protective film to the cutting mat to prevent debris from sticking to it and to maintain its adhesive properties.**

5.3 Install the cutting module-H2D/H2D Pro/H2C

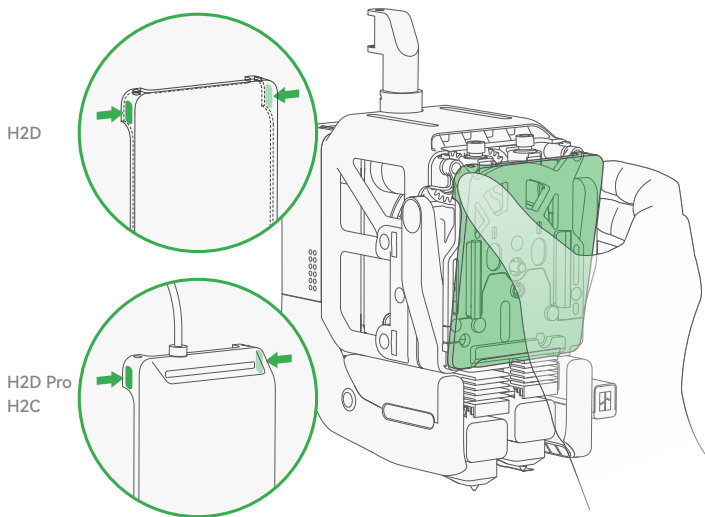

- 1) H2D: Press the two top corners of the front cover and remove it.
H2D Pro/H2C: Disconnect the connector of the toolhead enhanced cooling fan, and press the two top corners to remove it.

5.3 Install the cutting module-H2D/H2D Pro/H2C

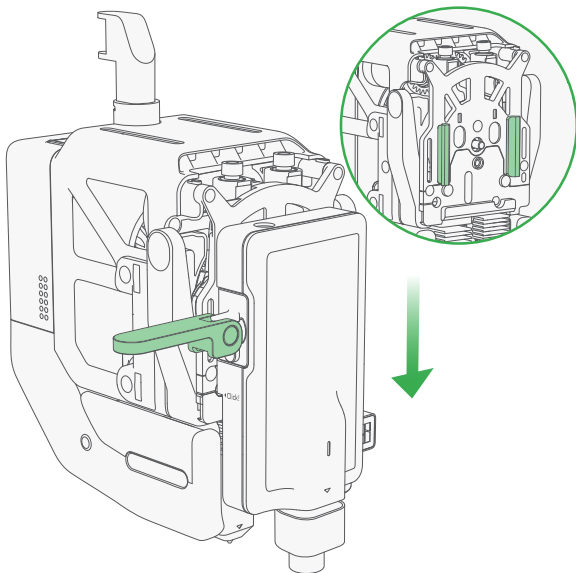

- 2) As shown in the picture, unlock the quick-release lever. Then, align the slots of the cutting module and the toolhead, and slide the module all the way down.

5.3 Install the cutting module-H2D/H2D Pro/H2C

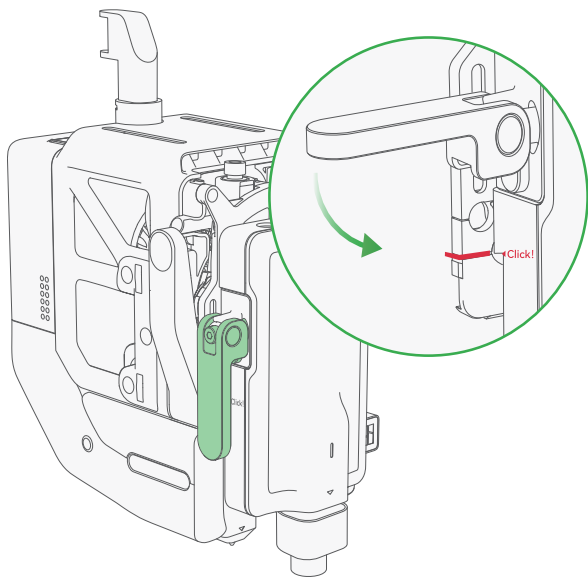

- 3) As shown in the picture, make sure the "Click" mark on the module is aligned with the dented slot on the toolhead. Then, push the quick-release lever down to lock it.

5.3 Install the cutting module-H2D/H2D Pro/H2C

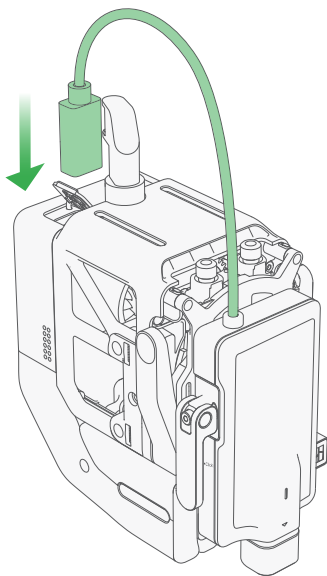

- 4) Open the dust-proof cover, and insert the connector into the toolhead interface.

5.3 Install the cutting module-H2D/H2D Pro/H2C

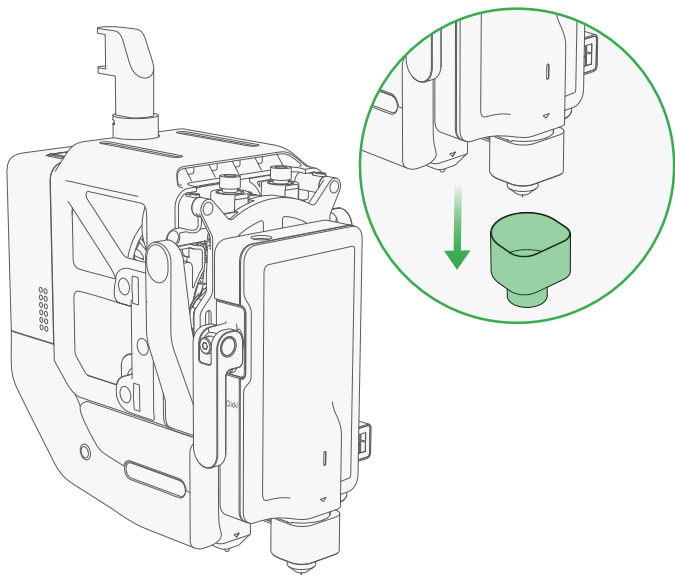

- 5) Remove the protective cover on the blade holder.

Caution! Sharp blade! Please carefully operate to avoid injury. Keep the protective cover safe to re-attach it when the blade is not in use.

5.4 How to use the drawing function-H2D/H2D Pro/H2C

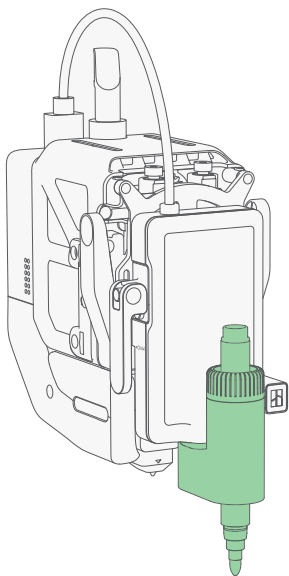

If you want to use the drawing function, you only need to replace the blade holder with the pen module.

5.5 Install the pen module-H2D/H2D Pro/H2C

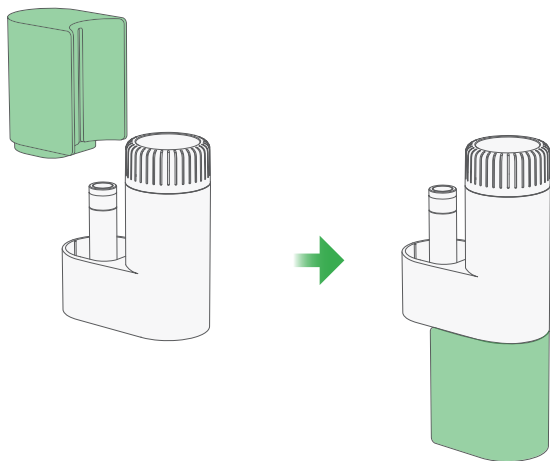

- 1) Remove the height calibrator from the pen holder, and install it on the bottom.

5.5 Install the pen module-H2D/H2D Pro/H2C

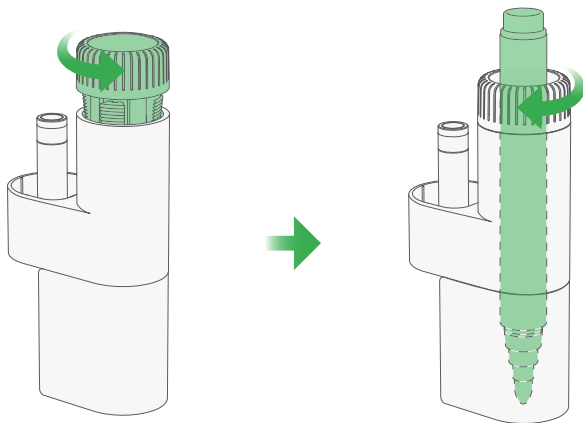

- 2) Rotate the pen fixture counterclockwise to loosen it. Insert a pen to the bottom, and then rotate the fixture clockwise to tighten it.

5.5 Install the pen module-H2D/H2D Pro/H2C

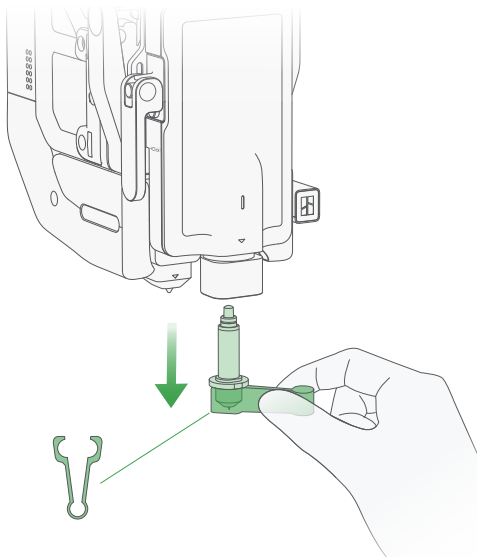

- 3) Use the blade holder unloader to pull the blade holder downward by the round edges to remove it.

The blade is sharp. Please operate carefully to avoid injury!

5.5 Install the pen module-H2D/H2D Pro/H2C

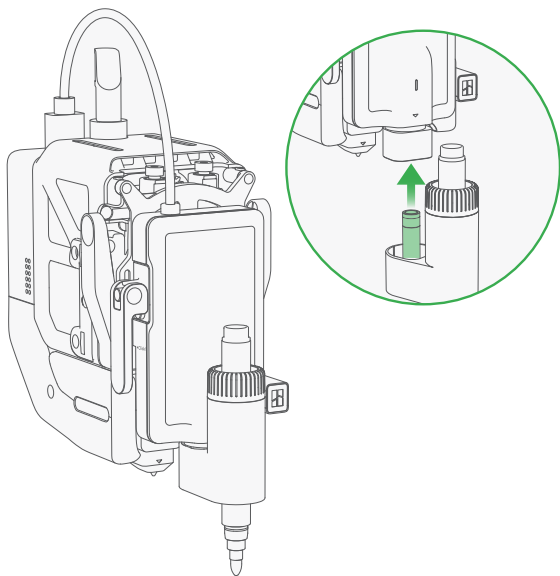

- 4) Insert the pen module all the way into the cutting module. Then, remove the height calibrator.

6. Install on H2S

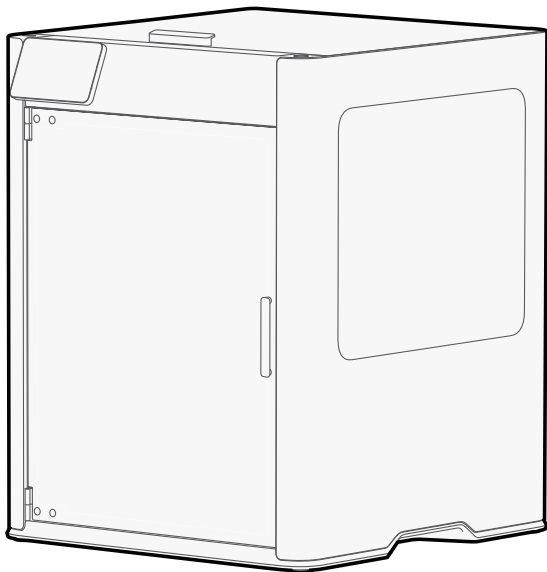

The installation instructions in this section apply to the H2S.

6.1 Lower the heatbed

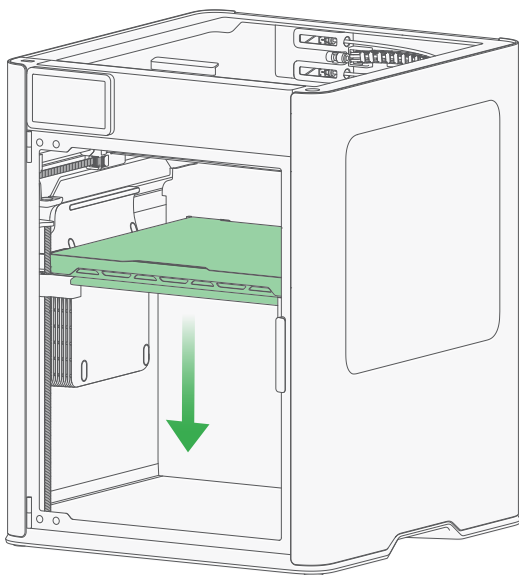

Lower the heatbed using the on-screen buttons to leave enough space to prevent the blade from damaging the cutting platform.

6.2 Install the cutting platform

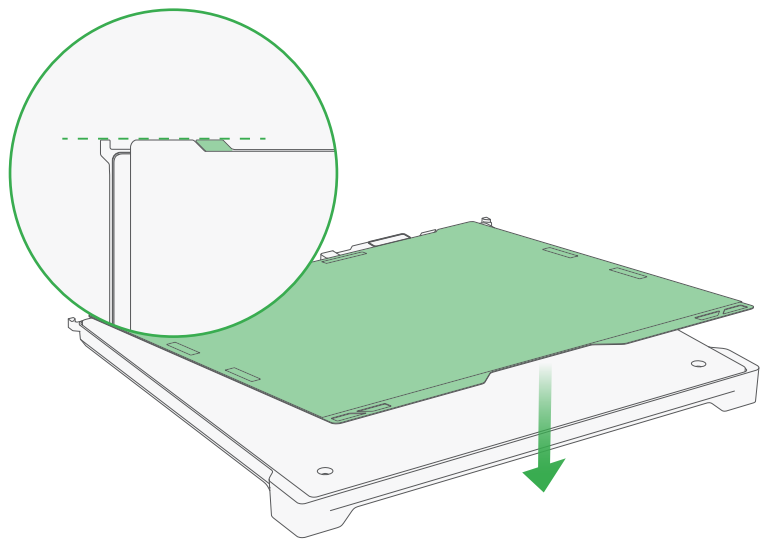

Remove the build plate on the heatbed. Then, place the cutting platform on the heatbed, and make sure to align the two corners of the cutting platform and the stoppers of the heatbed. **Do not discard the protective films on both the cutting mats. After use, reapply the protective film to the cutting mat to prevent debris from sticking to it and to maintain its adhesive properties.**

6.3 Install the cutting module-H2S

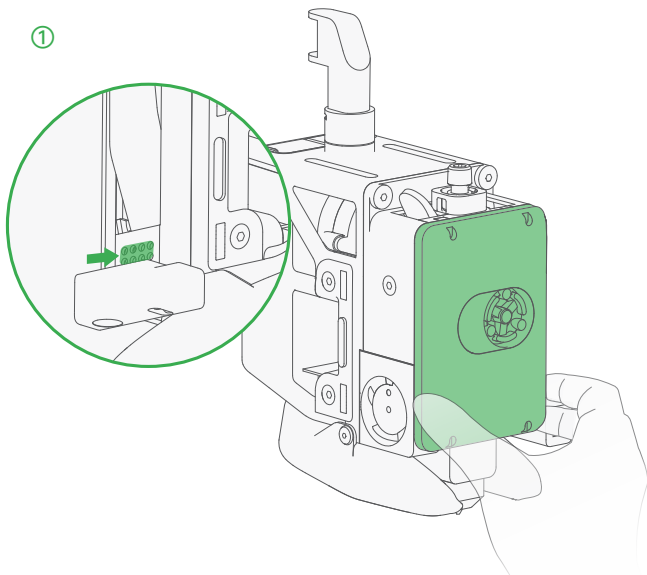

- 1) Press the lower-right corner of the front cover to remove it.

6.3 Install the cutting module-H2S

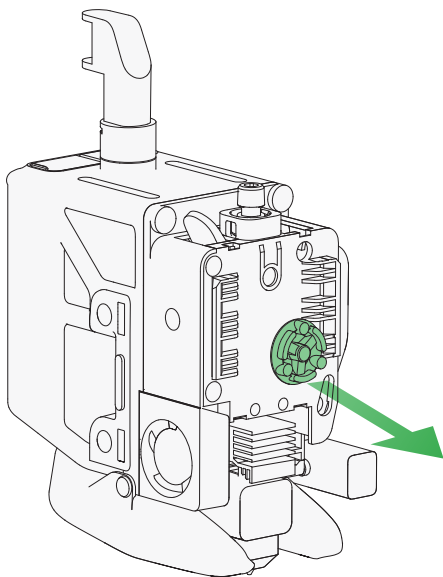

2) Pull out the rotating wheel.

6.3 Install the cutting module-H2S

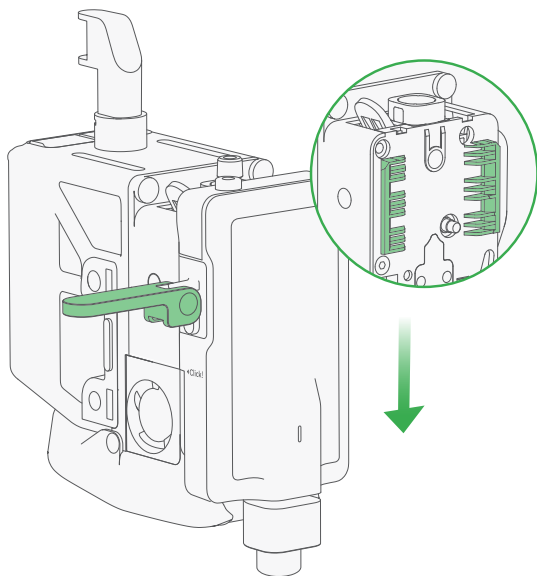

- 3) As shown in the picture, unlock the quick-release lever. Then, align the slots of the cutting module and the toolhead, and slide the module all the way down.

6.3 Install the cutting module-H2S

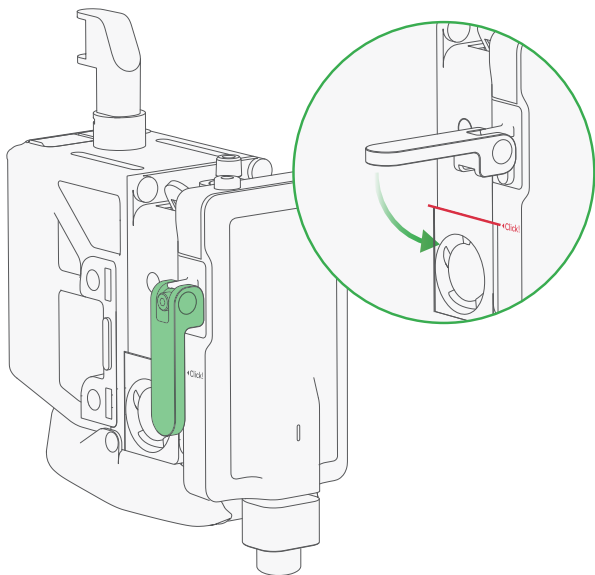

- 4) As shown in the picture, make sure the "Click" mark on the module is aligned with the upper edge of the hotend cooling fan. Then, push the quick-release lever down to lock it.

6.3 Install the cutting module-H2S

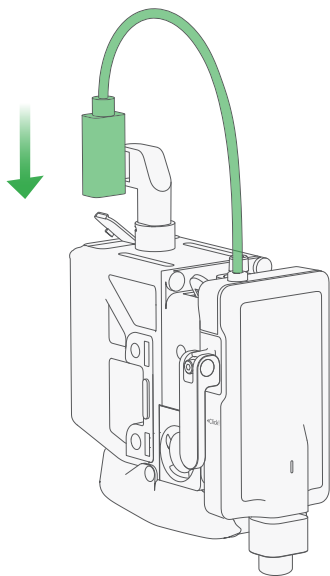

- 5) Open the dust-proof cover, and insert the connector into the toolhead interface.

6.3 Install the cutting module-H2S

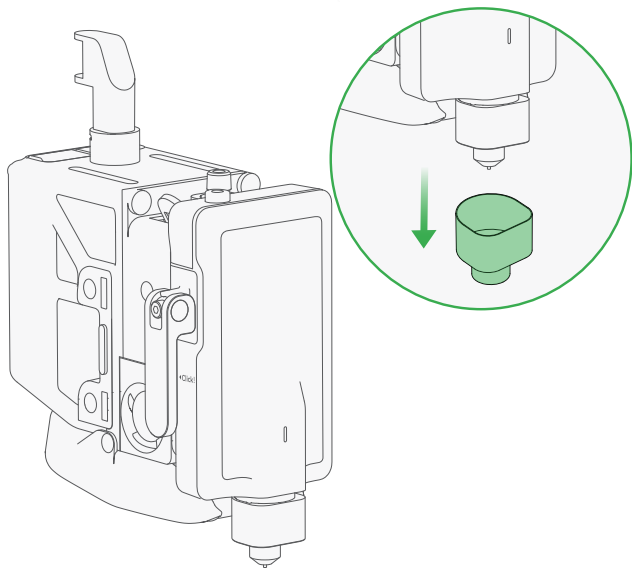

- 6) Remove the protective cover on the blade holder.

Caution! Sharp blade! Please carefully operate to avoid injury. Keep the protective cover safe to re-attach it when the blade is not in use.

6.4 How to use the drawing function-H2S

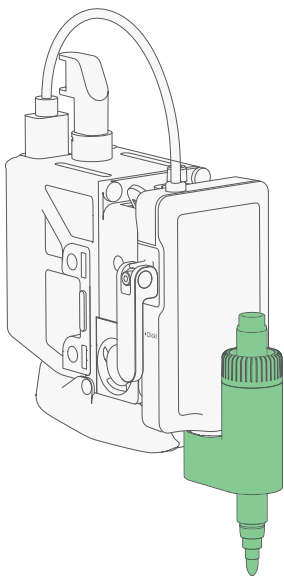

If you want to use the drawing function, you only need to replace the blade holder with the pen module.

6.5 Install the pen module-H2S

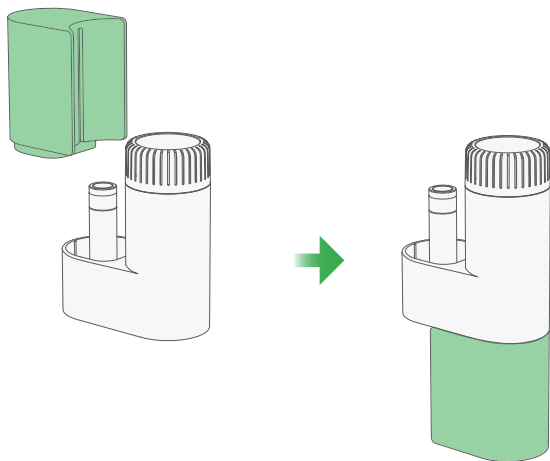

- 1) Remove the height calibrator from the pen holder, and install it on the bottom.

6.5 Install the pen module-H2S

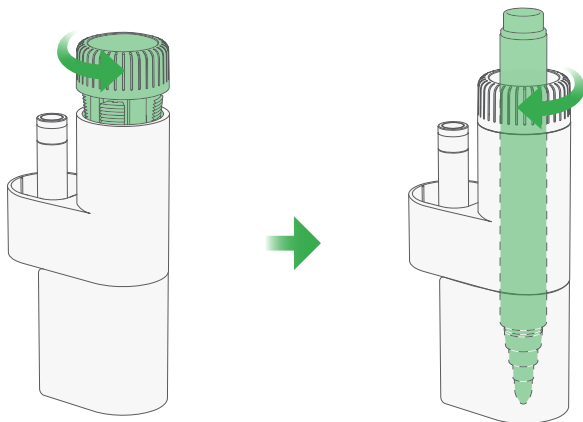

- 2) Rotate the pen fixture counterclockwise to loosen it. Insert a pen to the bottom, and then rotate the fixture clockwise to tighten it.

6.5 Install the pen module-H2S

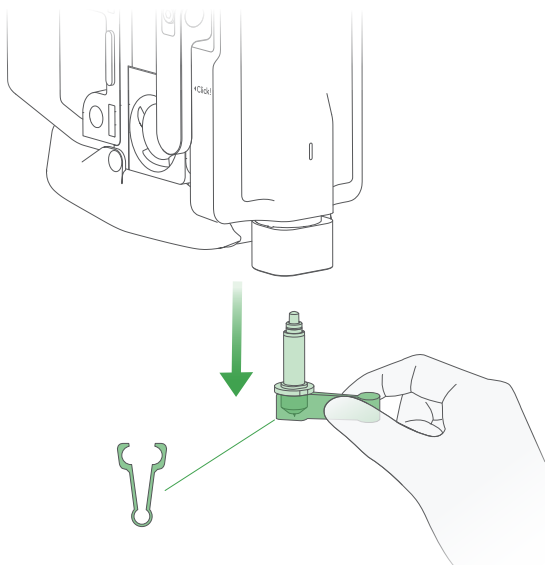

- 3) Use the blade holder unloader to pull the blade holder downward by the round edges to remove it.

The blade is sharp. Please operate carefully to avoid injury!

6.5 Install the pen module-H2S

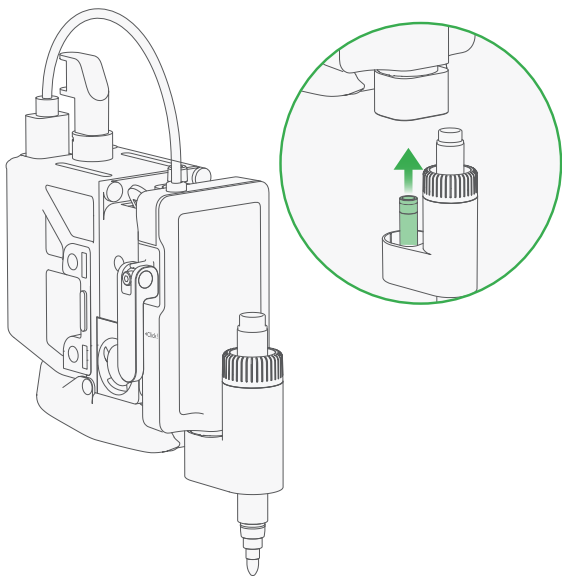

- 4) Insert the pen module all the way into the cutting module. Then, remove the height calibrator.

7. Install on A2L

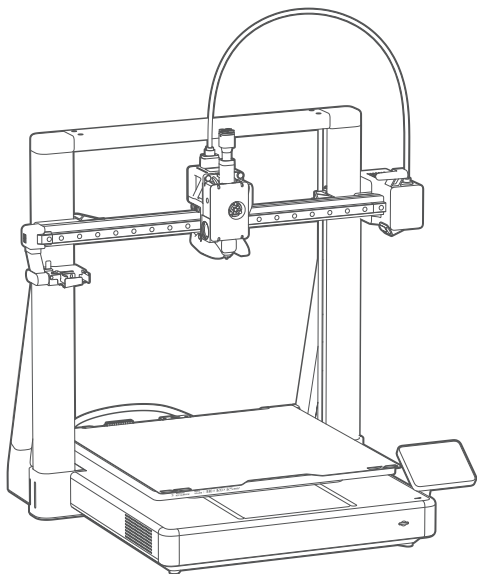

The installation instructions in this section apply to the A2L.

7.1 Raise the toolhead height

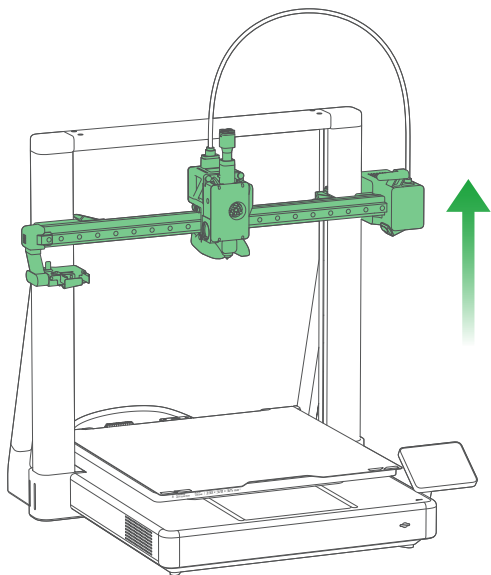

Raise the toolhead height on the screen to leave enough space and prevent the blade from damaging the cutting platform.

7.2 Install the cutting platform

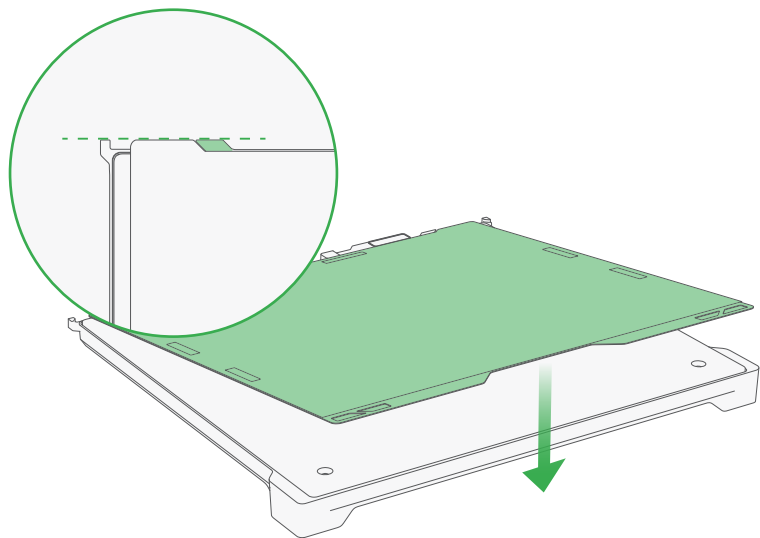

Remove the build plate on the heatbed. Then, place the cutting platform on the heatbed, and make sure to align the two corners of the cutting platform and the stoppers of the heatbed. **Do not discard the protective films on both the cutting mats. After use, reapply the protective film to the cutting mat to prevent debris from sticking to it and to maintain its adhesive properties.**

7.3 Install the cutting module-A2L

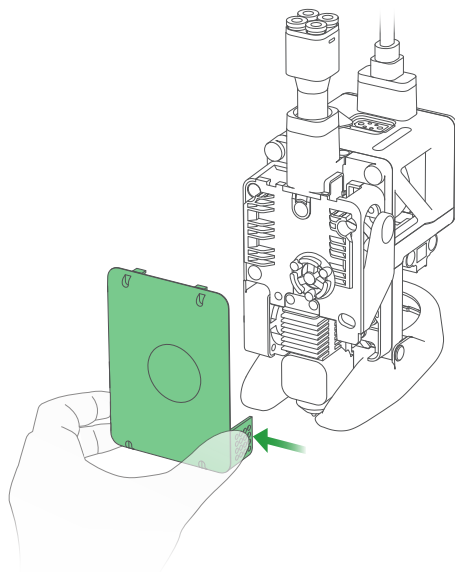

- 1) Press the two top corners of the front cover and remove it.

7.3 Install the cutting module-A2L

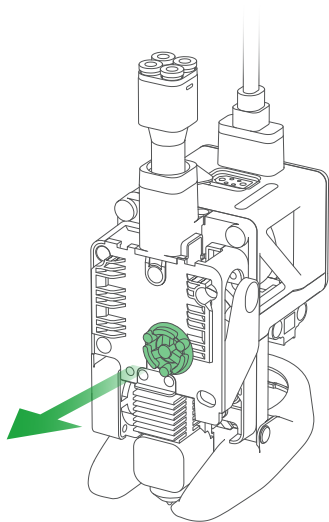

2) Pull out the rotating wheel.

7.3 Install the cutting module-A2L

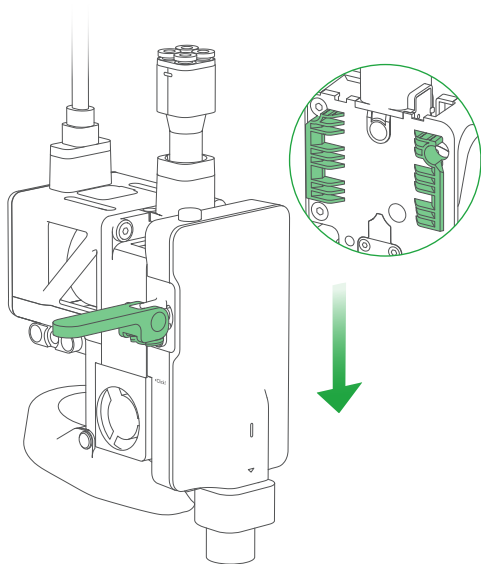

- 3) As shown in the picture, unlock the quick-release lever. Then, align the slots of the cutting module and the toolhead, and slide the module all the way down.

7.3 Install the cutting module-A2L

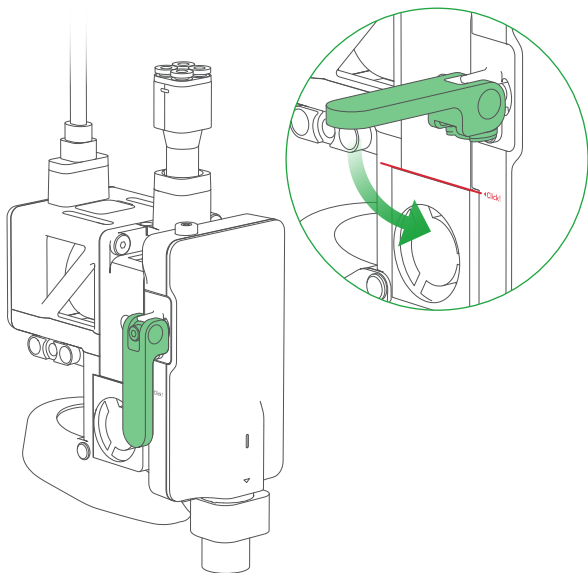

- 4) As shown in the picture, make sure the "Click" mark on the module is aligned with the upper edge of the hotend cooling fan. Then, push the quick-release lever down to lock it.

7.3 Install the cutting module-A2L

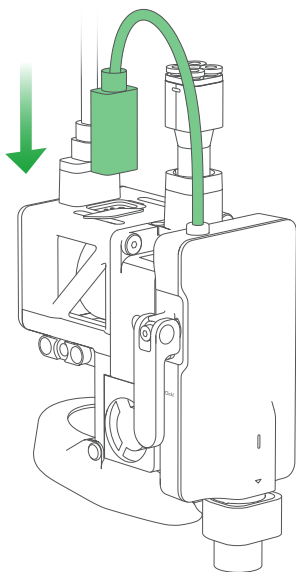

- 5) Open the dust-proof cover, and insert the connector into the toolhead interface.

7.3 Install the cutting module-A2L

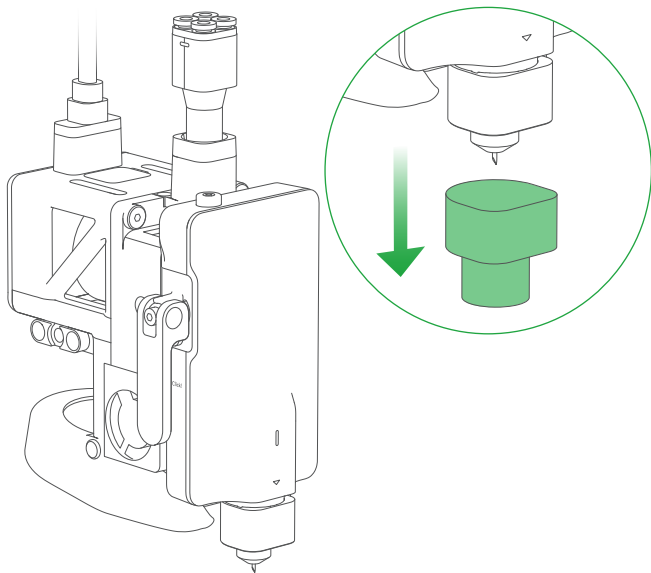

- 6) Remove the protective cover on the blade holder.

Caution! Sharp blade! Please carefully operate to avoid injury. Keep the protective cover safe to re-attach it when the blade is not in use.

7.4 How to use the drawing function-A2L

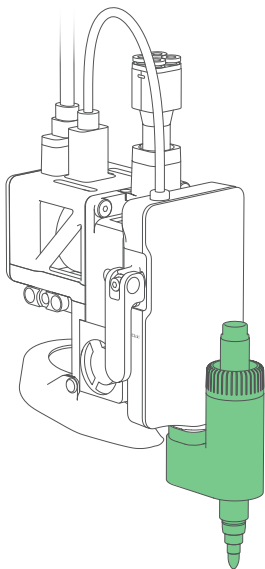

If you want to use the drawing function, you only need to replace the blade holder with the pen module.

7.5 Install the pen module-A2L

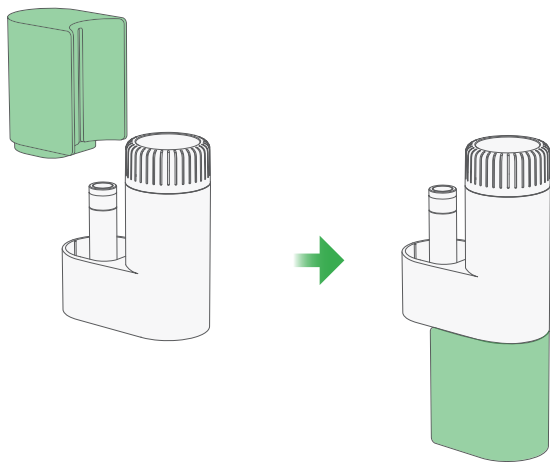

- 1) Remove the height calibrator from the pen holder, and install it on the bottom.

7.5 Install the pen module-A2L

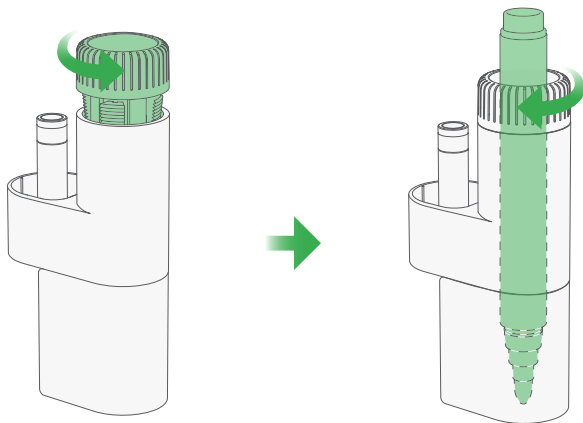

- 2) Rotate the pen fixture counterclockwise to loosen it. Insert a pen to the bottom, and then rotate the fixture clockwise to tighten it.

7.5 Install the pen module-A2L

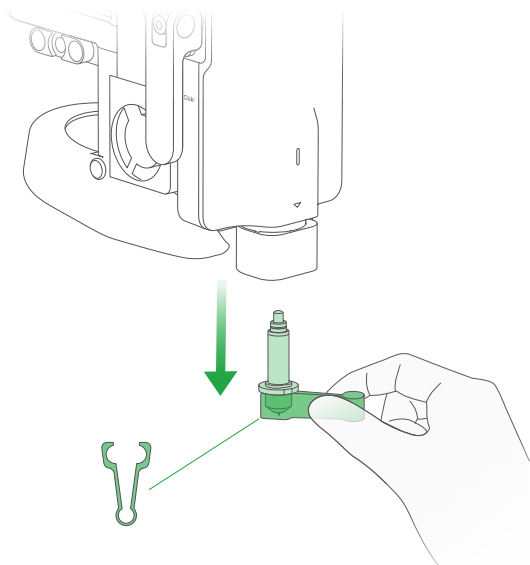

- 3) Use the blade holder unloader to pull the blade holder downward by the round edges to remove it.

The blade is sharp. Please operate carefully to avoid injury!

7.5 Install the pen module-A2L

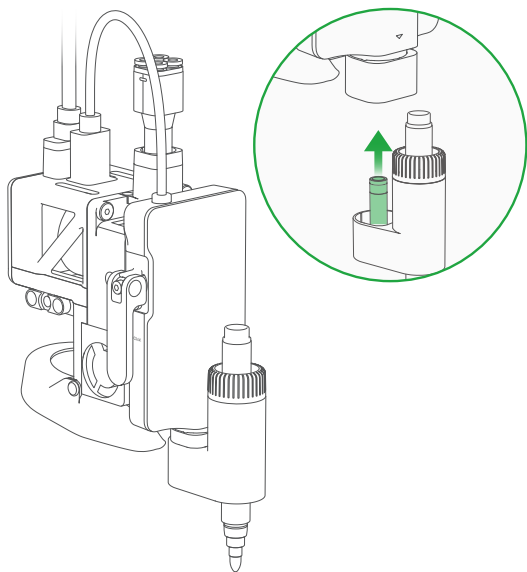

- 4) Insert the pen module all the way into the cutting module. Then, remove the height calibrator.

8. First calibration and use

After you install the cutting module for the first time, you must complete the calibration process before using it. Please follow the instructions on the screen to complete the process. For more details on calibration and use of the function, please see the Wiki page below.



wiki.bambulab.com/h2/manual/cutter-setup

9. Regular maintenance

Regular maintenance is essential to ensure the cutting module's longer lifespan and optimal performance.

Cutting module base:

Regularly inspect the base to ensure it is properly installed on the toolhead. After locking the quick-release lever, verify that the module is stable and does not wobble. If any wobbling is detected, tighten the screws on the quick-release lever.

Blade holder:

Regularly check for debris near the blade. If there is any, unscrew the end cap to remove the debris to prevent buildup that can obstruct the blade's rotation.

Consumables:

- Regularly check the adhesion of the cutting mat and replace it when necessary to ensure the material can be securely held in place.
- Over time, the blade will wear down, resulting in cutting quality decline. Replace the blade regularly to maintain optimal performance.
- The lifespan of the blade can vary depending on the materials being cut. For more details, please refer to our wiki.



bambulab.com/support/maintenance

Please refer to the "Regular Maintenance Recommendations" section on our wiki for more information.

10. Specifications

Item	Specification
Cutting Area	H2D/H2D Pro/H2C: 300*285 mm H2S: 297.5*300 mm A2L: 300*300 mm
Drawing Area	300*255 mm
Supported Pen Diameter	10.5 mm–12.5 mm
Cutting Mat Type	LightGrip and StrongGrip Cutting Mats
Blade Type	45°*0.35 mm
Blade Pressure Range	50 gf–600 gf
Max Cutting Thickness	0.5 mm
Blade and Pen Recognition	Supported
Cutting Mat Type Detection	Supported
Supported Image Type	Bitmap and Vector Images

11. Technical Support

If you need technical support, please follow any of the following methods:

Method 1: Visit the Bambu Lab Wiki for tutorials and maintenance guidance.

wiki.bambulab.com/home



Method 2: Get in touch through one of the options listed in the Contact Us section of our Support Center.

bambulab.com/support



Method 3: Create a support ticket on Bambu Handy, from the Support Center section.

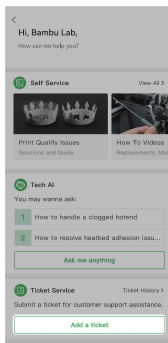
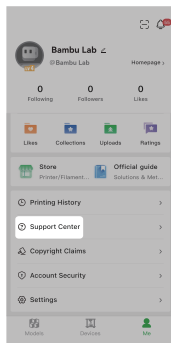



Bambu Lab

www.bambulab.com

